

the
LEON AUDIO
company

62 Edgeware Road, Aldgate, South Australia, 5154. Phone +61 8 8339 3865 Fax +61 8 8370 8780 www.LeonAudio.com.au

8/14 Channel Digital Theatre Cue Light



An easy to use Cue Light system allows Outstations to be daisy chained on a single cable for fast setup.
2 Master Groups allow simple 1 button cues.
Reports cable faults.
8 and 14 channel versions.
All metal, low profile Outstations have flush LEDs.
Relay and Beeper Outstation options.
RS232 Remote Control Interface option.
Custom options available.

An Overview



14 ch Master QLM14 Mk3



8 ch Master QLM8 Mk3



QLS Mk3



QLS-SMMk3



QLS-BMk3



QLR Mk3



QL-RS232

The system consists of a Master Control Unit and any number of Outstations up to a maximum of 14 per Master Unit.

The Master Unit is available in 8 and 14 channel versions.

Outstations are available individually.

Up to 8 Master Units can be linked for larger systems providing a maximum of 112 Outstations.

Outstations are digitally addressed and can be wired using either daisy chain, star and/or loop wiring topologies on a single 3 pin XLR microphone cable for fast and easy setup. The loop configuration allows the whole system to keep working even when a break in the cable exists. CAT5/6 cable may also be used with suitable adaptors.

There are four varieties of Outstations available:

1: Standard Outstation. Model QLS Mk3

Provides Go and Standby LEDs, and an Acknowledge button.

The intensity of the Go and Standby LEDs are adjustable in 5 steps from 20 to 100%.

It has the ability to signal the Master Unit.

2: Standard Outstation, small footprint. Model QLS-SMMk3

As per the Standard Outstation, but smaller. It has a permanently attached 1m cable fitted with a 3 pin male XLR connector.

Go and Standby LEDs are 5mm in diameter.

3: Beeper Outstation. Model QLS-BMk3

As per the Standard Outstation, but with an inbuilt beeper for use when the talent nods off. A discrete "click" sound or a longer beep can be triggered from the Master. The beep function can also be globally disabled on the Master. See "Master Setup" in the Maintenance section for details. It functions as a Standard Outstation at all other times.

4: Relay Outstation. Model QLR Mk3

This Outstation has two relays with changeover contacts which are controlled by the Go and Standby buttons on the Master Unit.

Connection to the voltage free relay contacts is via a locking 8 pin metal connector. Two modes of operation are selected by a link on the 8 pin relay connector.

Mode 1: One relay is Momentary acting and the other is Latching.

Mode 2: Cue Light Mode.

RS232 Remote Control Interface. Model QL-RS232

Connects between a Master Control Unit and a PC to provide remote control for up to 8 Cue Light Master Stations via RS232 from 3rd party show control software.

With 14 channels per Master, that's a total of 112 Outstations that can be individually controlled.

Typical Operation

- 1: Stage manager presses a Standby button on the Master Unit.
Standby LEDs on both Master & Outstation flash.
- 2: The talent presses the Outstation's Acknowledge button which causes the Standby LEDs to burn steadily.
- 3: Stage manager presses the Go button.
The Go LED lights. The Standby LED goes out if it was on.
After 3 seconds the Go LED starts to flash quickly. After a total of about 12 seconds, the Go LED turns itself off.

The Go or Standby lights can be turned off at any time by pressing their respective buttons a second time.

It is not necessary to use the Standby Light before activating the Go Light. Multiple tight Go cues are simply done by using the Go button only. Press Go to turn the Go Light on. Press it again a few seconds later to turn the Go Light off. Repeat for the next cue.

Master Unit



Master Unit controls.

Each channel on the Master Unit has 3 buttons and 5 LEDs. A white designation strip runs beneath all channels.

Go and Standby buttons.

Used to light a *Go* or *Standby* LED on an Outstation. The Go and Standby buttons have corresponding LEDs which respond to the data returned from the Outstations. They are not just an indicator that a button has been pressed locally.

Group Function.

Any or all of the channels can be assigned to one of two group master Go and Standby buttons. The two group masters are designated *A* and *B*. The group assignment for a channel is controlled by the grey Group button and two associated yellow LEDs.

Pressing the grey Group button cycles through four possible group assignments: *A*, *B*, *A+B* and none.

Pressing either of the group master *Go* or *Standby* buttons, is exactly the same as pressing the corresponding button on any channel that has been assigned to that group master.

Master Unit. (continued)



Group Function (cont.)

The channel's Go and Standby buttons still remain fully operational independent of any group assignment.

The status of each channel's Group button is saved in EEPROM and is restored when the Master Unit is powered up.

When multiple Master Units are used, the group master buttons can be linked via an *expansion port* on the rear panel. When linked, pressing any of the four group master buttons on any Master Unit will *press* the corresponding group master button on all linked Master Units.

Up to 12 Master Units can be linked for larger systems providing a maximum of 168 Outstations.

Note: The RS232 Interface unit can only control up to 8 Master Units, providing a maximum of 112 Outstations under RS232 control.

Fault LED.

A red Fault LED at the top of each channel indicates when an Outstation is not communicating with the Master Unit. This could be due to an unplugged Outstation or a cable fault.

The Fault LED has 3 states. On, off and flashing.

1: The Fault LED is on if the channel has never had an Outstation connected. (unused channel)

2: The Fault LED is off if the channel has an Outstation connected.

3: The Fault LED flashes if the Outstation *was* connected but has failed or become disconnected.

The Master Unit and each of the Outstations are in continuous communication with each other, enabling prompt detection of cable faults or missing Outstations. Positive monitoring is used whereby all LEDs on the Master Unit are driven in response to replies from the various Outstations.

Master Unit. (continued)



There are two special function buttons at the top right of the Master Unit. They work like a *shift key* in conjunction with a channel's Go and Standby buttons.

Beep Button.

This function requires the Beeper Outstation (Model QLS-B) which is basically a standard outstation fitted with a beeper. It functions just like the standard outstation when the Master's beep button isn't pressed. The beeper can be triggered to emit either a discrete "click" sound (a very short beep), or beep for as long as the button is pressed, up to a maximum of one second.

The Beep button functions like the Shift key on a computer keyboard. Pressing both the Beep and Standby buttons sounds the very short beep. Pressing both the Beep and Go buttons sounds the long beep.

All Outstations have any cues suspended and their LEDs turned off while the Beep button is pressed.

The beep is accompanied by flashing of the Standby LED of the triggered Outstation(s). The Beep button can also be used in conjunction with the group master buttons.

The beep function can be globally disabled on the Master Unit. See "Master Setup" in the Maintenance section for details.

Dimmer Button.

The Outstation LEDs can be dimmed in five steps from 20 to 100%. Press and hold the Dimmer button. Use the Standby button to increase intensity, and the Go button to decrease intensity.

Once 20% or 100% is reached, further presses are ignored. Four presses of the Standby button will set an Outstation to 100% irrespective of its initial setting. The Dimmer button can also be used inconjunction with the group master buttons.

The Go and Standby LEDs on the selected Outstation flash alternately as the intensity is adjusted.

The intensity can also be adjusted from an Outstation.

Press and hold the dimmer button.

Pressing the Acknowledge button on an Outstation starts the Go and Standby LEDs flashing alternately. Subsequent presses of the Acknowledge button increase the intensity by 20%. When 100% is reached, it rolls back to 20%.

The dimmer settings are stored in EEPROM in each of the Outstations.

When the Dimmer button is pressed, any active cues are cancelled. A short press of the Dimmer button by itself can also be used as a *cancel all cues* function.

Master Unit. (continued)

Short LED.

The Short LED, just below the Power LED, indicates short circuits on the external XLR wiring. Fault current is electronically limited to approximately 1.5 amps.

If the short is maintained for more than 400mS, the power supply enters a hiccup mode to limit the power dissipation of the internal current limiter. The power is removed from the Outstations and is reapplied after a few seconds. If the fault is still present, power is again removed. The period before reapplying power increases from 2 seconds to 8 seconds over a 45 second period. This is to limit the long term power dissipation of the current limiter.



Rear views of the Master Unit.



The Rear Panel.

Parallel male and female 3 pin XLR connectors are provided for connection to the Outstations using ordinary microphone cables.

Parallel 4 pin locking connectors are used for the *expansion port* which is used to link the group master buttons on multiple Master Units. When linked, pressing any of the four group master buttons on any Master Unit will *press* the corresponding group master button on all linked Master Units.

Up to 12 Master Units can be linked for larger systems providing a maximum of 168 Outstations.

The Expansion Port cables can be up to a total of 30 metres (100 feet) in length if required. The XLR cables to the Cue Lights can be at least 1,000 metres (3,300 feet) long in total.

Four core unscreened cable is suitable for expansion port cables less than 2-3 metres long.

Star quad cable is ideal for longer expansion port cables.

Wire the lead as follows:

Pin 1: Screen (Common)

Pin 2: Both white wires (+ve DC)

Pin 3: First blue wire (RS485 -ve)

Pin 4: The other blue wire. (RS485 +ve)

You'll need a meter to identify the individual blue wires so as to get them the right way round..

If you want to steal power from the expansion port, here are the rules...

Pin 1: 0V. Also connected to pin 1 on the XLRs.

Pin 2: Filtered but unregulated DC.

The DC voltage could be anywhere from 24 to 35V depending on the Master Unit's power supply.

Pin 2 is diode isolated and fed via a current limiter. Short circuit current is limited to approximately 150mA.

Pin 2 will provide 100mA continuously without problems.

Pin 2's supply is derived from the main DC supply which feeds the Outstations and will be switched on and off when cable shorts occur.

Outstations



Small Footprint Outstation.
Model QLS-SM Mk3

Standard Outstation.
Model QLS Mk3

- Anywhere from 1 to 14 remote Outstations can be connected.
- Flush mounted Acknowledge button and LEDs are virtually impossible to break or shear off.
- High intensity wide angle 20mm diameter LEDs for excellent visibility and high reliability. Almost 180° viewing angle.
- Acknowledge button is back lit so you can find it in the dark.
- The back light only comes on when error free communication is established with the Master Unit, providing a cable integrity check.
- Individually numbered to correspond to the Master Unit's channels.
- Has the ability to signal the Master Unit when idle.
- The address of any Outstation can be changed in a few seconds without the use of any tools or fiddly DIP switches.
- Ability to daisy chain from one Outstation to the next.
- Outstations can be wired up in any physical sequence. Outstation #2 does not have to follow #1 in a daisy chain.
- Outstations can be added or removed while the power is on.
- Die cast aluminium case has flanges top and bottom with a total of 4 mounting slots.

The Small Footprint Outstation is functionally identical to the Standard Outstation. The major mechanical differences are:

- Width: 110mm (4.3") Height: 58mm (2.3") Depth: 30mm (1.2")
- 5mm wide angle high intensity LEDs
- Rubber feet instead of mounting flanges.
- Permanently attached 1m cable with 3 pin male XLR connector.

Beeper Outstation. Model QLS-B Mk3

The Beeper Outstation is identical in appearance to the Standard Outstation with the exception of a small hole on the side of the case for the beeper. For use of the beeper see *Beep Button* under the Master Unit section.

Signalling the Master.

Any Outstation can signal the Master Unit when no cues are active. Pressing the Acknowledge button will flash both Go and Standby LEDs on the corresponding channel on the Master Unit.

This signalling feature can be globally disabled at the Master Unit. See "Master Setup" in the Maintenance section for details.

Outstation Address.

The address of an outstation can be reprogrammed without the use of any tools. For details see the Maintenance section later in this document.

Outstations. (continued)

Cue Relay Outstation. Model QLR Mk3.



Relay Outstation.
Model QLR Mk3.

The Relay Outstation provides two changeover relays wired in parallel with small Go and Standby LEDs respectively.

The relays are controlled by the Go and Standby commands from the Master Unit.

The relay contacts are voltage free and are rated at 1amp 30 volts AC or DC. They are brought out on a locking 8 pin metal connector on the side of the case.

There are two modes of operation determined by a link wired between pins 7 and 8 of the 8 pin Relay connector.

Latching/momentary Mode (No link fitted between pins 7 & 8)

Relay 'A' is controlled by the Standby button. It is momentary acting which means that it is energized as long as the Standby button is pressed. Relay 'B' is controlled by the Go button. It is latching which means that it toggles every time the Go button is pressed.

What was the Acknowledge button on the Standard Outstation, is now only used for changing the unit's address and for signalling the Master Unit. The Master can only be signalled when no relays are energized.

Cue Light Mode (Link fitted between pins 7 & 8)

The relays behave in the same manner as the Go and Standby lamps in a standard Outstation. In this mode, the button also functions as an 'Acknowledge' button.

THE RELAY CONTACTS ARE NOT SUITABLE FOR DIRECT CONNECTION TO MAINS WIRING.

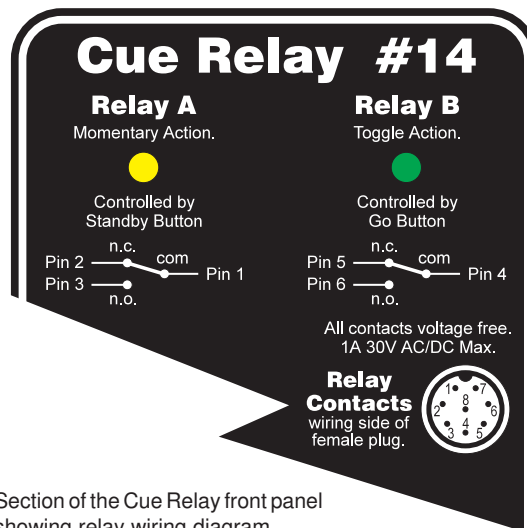

Section of the Cue Relay front panel showing relay wiring diagram.



Relay Connector.

Spare 8 pin plugs are available from many electronic suppliers.

They are also available from The Leon Audio Company and Altronics. <http://altronics.com.au>
Product code P0952.

External Wiring for Cue Relays

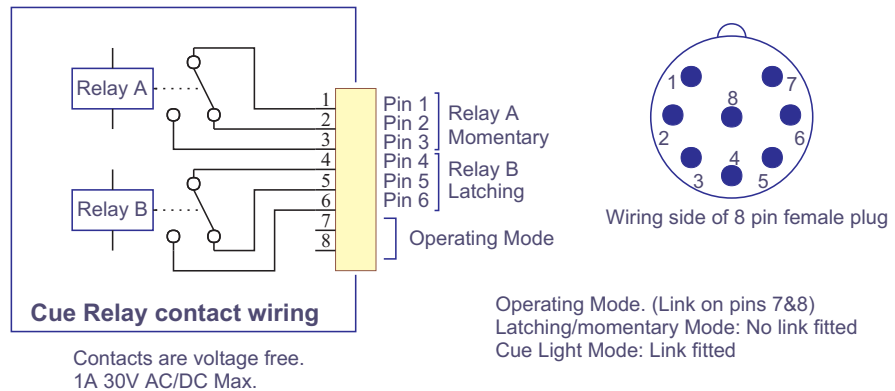

Cue Relay contact wiring

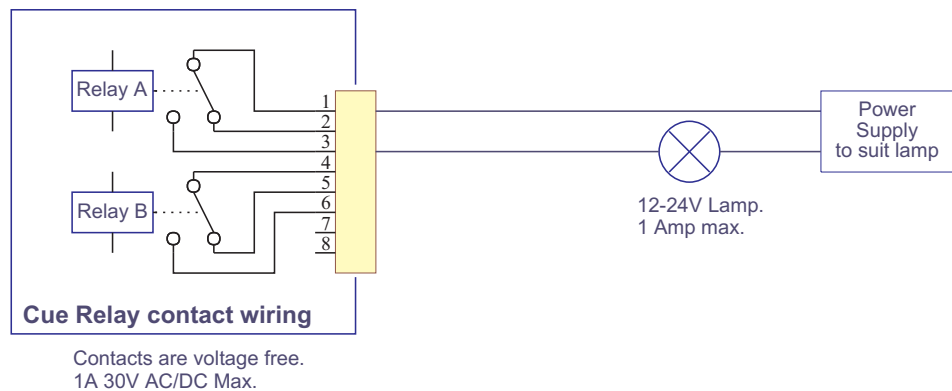

Cue Relay driving a low voltage lamp

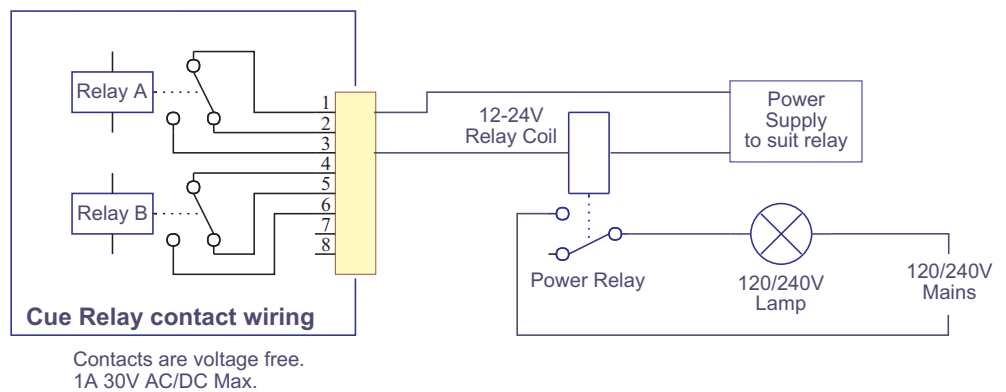

Cue Relay driving a mains voltage lamp

Custom Options

A number of Outstation variations are available.

The standard Outstation configuration is shown in green.
Please specify option(s) required at time of ordering.
Please contact us if your required option is not listed.

	Standard	Option
Standby Lamp Colour	Yellow	Red
Standby Lamp Flashing	Flashes	Does not flash
Go Lamp Flashing	Flashes	Does not flash
Go Lamp Time out	Times out after 15 seconds	Stays on
Acknowledge button backlight colour	Red	Blue

These options are available in any combination.

Cables

The Outstations may be wired using either daisy chain, star and/or loop wiring topologies.

The loop configuration allows the whole system to keep working even when a break in the cable exists.

Any combination of the above is permitted.

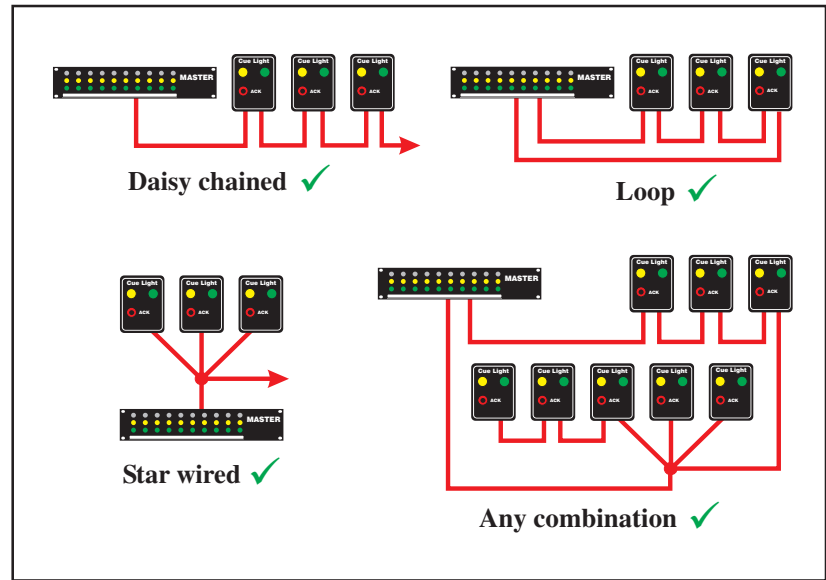

Acceptable wiring methods.

The system is designed to use industry standard 3 pin XLR microphone cables although low loss 1 pair data cable is preferred for long runs and permanent wiring.

Star Quad and multicore (snake) cables may be used. Digital snakes can not be used as they do not allow bi-directional signals or power to be sent down the cable.

CAT5/6 cable can also be used but it is unshielded and may be more susceptible to noise pickup from adjacent cables.

It is recommended to parallel multiple conductors to achieve a lower DC resistance. See "XLR to Cat5 adaptor" later in this document.

Limit the *total* cable length to 1000 metres.

The Outstation interconnections are low impedance, balanced, transformer coupled and use FM modulation for maximum immunity to external interference.

Even though the system is very resistant to interference, it is good engineering practice to install the Cue Light wiring away from mains wiring. Install it as though it were a microphone cable.

It will also work with cables wired with pins 2 & 3 swapped.

Outstations can be wired up in any physical sequence.

Outstation #2 does not have to follow #1 in a daisy chain.

They can be connected/disconnected while the power is on.

The Master Unit is mains powered. All of the Outstations are powered from the Master Unit via the interconnecting cables.

For permanent installations, it is permissible to have dozens or even hundreds of sockets spread around a venue. The Master Unit can be plugged into any one of these sockets. Outstations are then connected to the nearest convenient socket.

Cables. (continued)

The cheapest type of screened cable to use is 24 AWG 1 pair foil screened data cable. This is typically about 3.5mm (1/8") in diameter and is suitable for permanent wiring.

(AWG = American Wire Gauge. Lower AWG number = thicker cable)

For wiring between permanently installed 3 pin XLR outlets and the Outstations, ordinary microphone cables can be used.

The Outstations are powered from the Master unit via the cable.

The longer the cable run, the greater the power loss.

Fewer Outstations on the end of a cable allow a longer cable to be used.

Heavier cables such as 18-20 AWG allow more Outstations to be connected and/or longer distances to be covered.

The screen is the power return. Screens of thickness equal to or thicker than the signal wires are preferred.

The digital data is also attenuated; primarily by the cable's capacitance. Select cables with a core to core capacitance around 100pF/metre (30pF/foot) or less.

Avoid long cables which use PVC insulation for the inner conductors. PVC has high losses for digital signals.

Outstations Connected	Loop Resistance	24 AWG Metres	20 AWG Metres	CAT 5 Metres
14	15	120	500	320
8	26	220	900	580
4	50	420		1100
2	100	850		

Number of Outstations that can be connected to various cables.

Belden's "Blue Hose" range (9463 series) is a good example of 20 AWG screened cable. See the basic cable specification table later in this document.

The cable's characteristic impedance is not important as the Cue Light system does not use a terminated transmission line of fixed impedance.

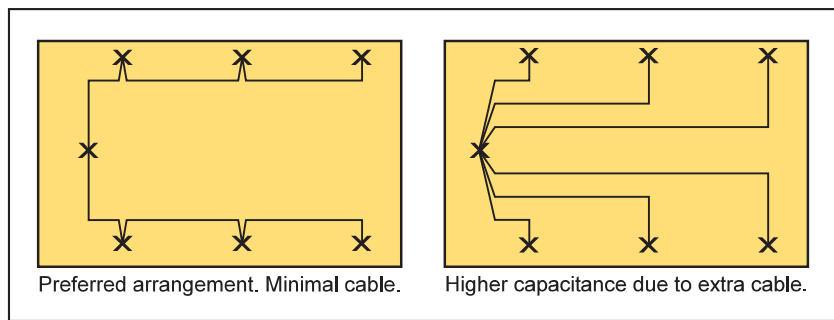

Minimize the total length of cable used.

Cable segments with nothing plugged into them still load the system because the cable's capacitance is still connected to the circuit.

Cables. (continued)

An installation example.

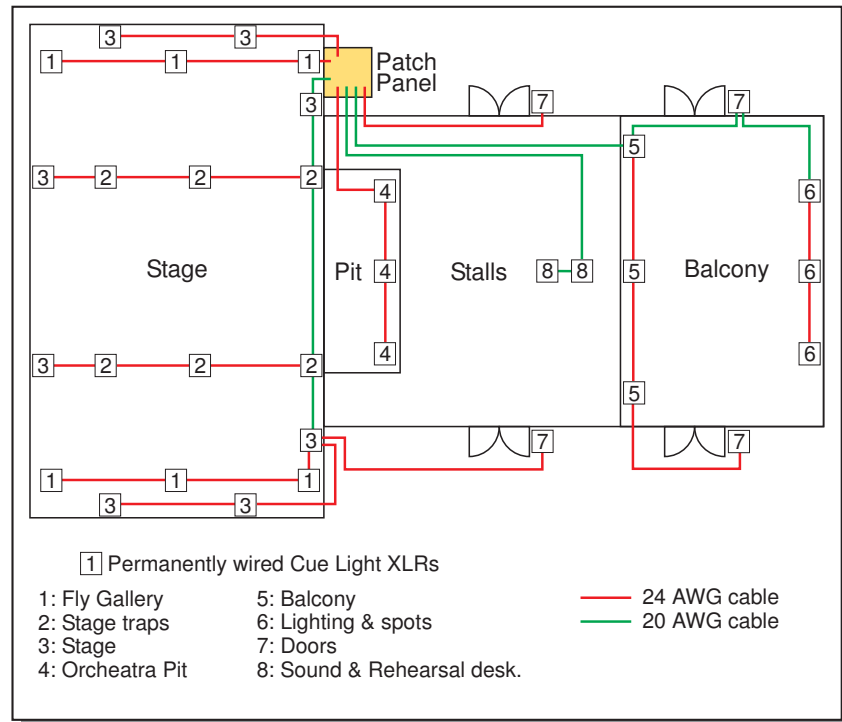

The example above shows how a theatre might be permanently wired to provide multiple Cue Light XLR points.

Backbone cable segments in green are wired with a thicker cable as these have a larger number of outlets attached to them.

The Master unit could be located at XLR points #8 during rehearsals. The cable between the patch panel and points #8 would have to carry 100% of the Outstation load, hence the thicker cable.

Small venues, or those using 8 or less Outstations, could be cabled entirely in 24 AWG cable.

Optional note for the technically inclined.

Mk3 Outstations draw a maximum of 60mA each.

Mk3 Relay Outstations draw a maximum of 120mA each. Count them as two standard Outstations.

Maximum voltage drop between the Master and any Outstation should be less than 12 volts.

Apply Ohm's law. $R = V/I$

Where I is the total Outstation current (in amps) on the cable run.

V = 12. The maximum voltage drop permitted.

R is the cable's loop resistance. Select a cable with a loop resistance equal to or less than that calculated.

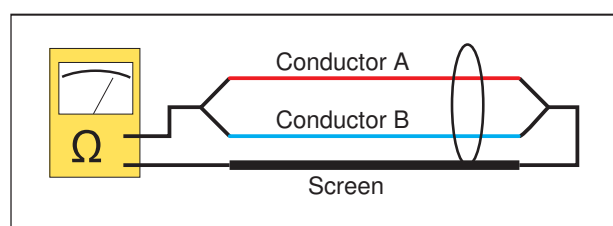

Measuring DC Loop resistance.

	Model	AWG	core/core capacitance pF/m	Conductor Resistance ohms/100m	Screen Resistance ohms/100m	Loop DCR ohms/100m	Notes
Canare canare.com	L-2E5AT	23	79.0	6.2	4.2	7.3	
	L-2B2AT	25	73.0	10.5	5.6	10.9	
Mogami mogami.com	3173	18	50.0	2.0	0.7	1.7	110Ω AES/EBU Digital Audio Cable
	3159	24	46.0	8.1	2.4	6.5	110Ω AES/EBU Digital Audio Cable
	3080	25	46.0	11.0	2.8	8.3	110Ω AES/EBU Digital Audio Cable
Belden belden.com Alphawire numbers in brackets (Alphawire.com)	9860 (9820C)	16	35.8	1.4	0.4	1.1	Very low loss. Braid & foil
	8760 (2421C)	18	98.0	2.2	3.1	4.2	
	9250 (9816)	18	52.5	2.2	0.3	1.4	RG-22B/U
	9463 (9814C)	20	64.6	3.1	1.3	2.9	Belden "Blue Hose" Foil + 55% Braid
	9463F	20	64.6	3.3	0.6	2.3	Flexible Blue Hose Foil + 85% Braid
	3105A	22	36.1	4.8	0.9	3.3	Braid + foil
	9501 (5471C)	24	131.0	7.9	5.9	9.8	High Capacitance
9841 (6412)	24	42.0	7.9	1.1	5.0	Braid + foil	
Electra electracables.com.au	EAS7201P	24	65.0	8.6	7.6	11.9	Cheap
Olex olex.com.au	JD1PS485A3	24	50.0	8.4	6.0	10.2	Braid + foil
Altronics altronics.com.au	W3035	24	154.0	8.0	6.5	10.5	
MISC	CAT5	24	38.0	4.5	2.2	4.5	Wired using all 8 cores as per adaptor.

Basic specifications for a selection of 1 pair screened cables.

XLR to CAT5 Adaptor

An XLR to RJ45 adaptor will allow the use of CAT5 cable for connecting the Outstations.

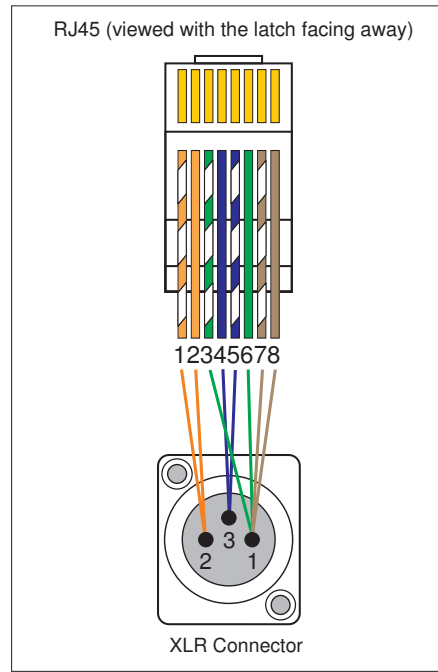

Suggested CAT5 adaptor wiring

This adaptor should not be used in locations where it could be accidentally cross patched with telephone or data services.

CAT5 cable is fine for permanently installed wiring. It is also widely used for temporary wiring which is not good engineering practice as CAT5 and its connectors are mechanically inferior to professional grade microphone cable and XLR connectors.

Screened CAT5 is preferred.

Connect the screen to XLR pin 1 at both ends.

14 Outstations will work at the end of 320 metres of cable.

8 Outstations will work at the end of 580 metres of cable.

6 Outstations will work at the end of 740 metres of cable.

A bit of technical stuff

The Master unit transmits a 16 bit word to each of the Outstations in turn. This 16 bit word contains the Outstation's address, *Go* and *Standby* button information as well as considerable redundant data used by the Outstation for verifying the integrity of the data. This redundant data provides a high degree of immunity to external electrical interference. The Outstations reply back to the Master Unit with the status of the Acknowledge Button and of the *Go* and *Standby* LEDs.

Data communication is via transformer coupled RS485. Frequency Modulation is used as regular serial data can not pass through data transformers. Nominal 30V DC power is sent as a common mode voltage over the same pair of wires as the data. The principle is similar to Phantom Powering of microphones. The data transformers also provide excellent CMRR for very good noise immunity.

The data is at a rate of approximately 10K Baud. This relatively low data rate allows very long cables to be used without the need for terminators or special cables as is the case with DMX.

Multiple Master Units

Each Master controls its own "universe" of up to 14 Outstations.

An 8 channel Master can be connected to 8 Outstations maximum.

An 14 channel Master can be connected to 14 Outstations maximum.

Outstations can be connected in any order.

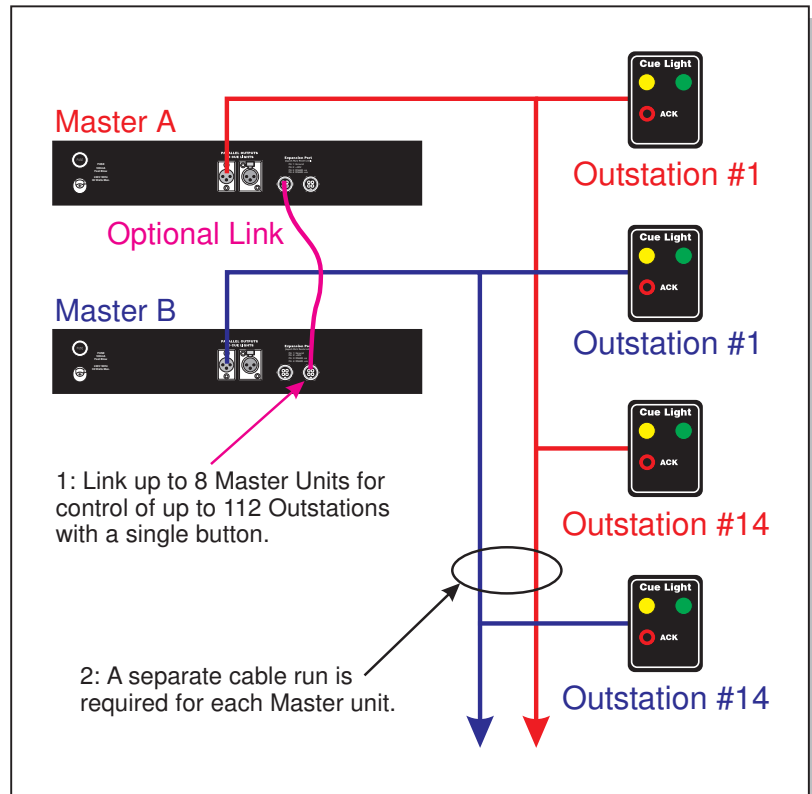

A separate cable run is required for each Master unit.

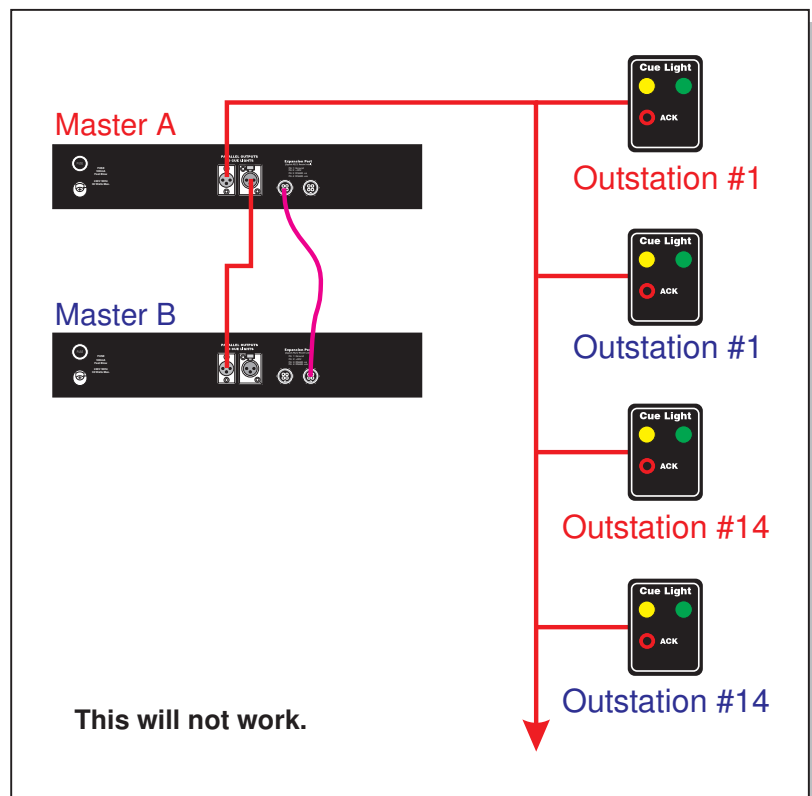

RS232 Remote Control Interface



QL-RS232



Rear view

RS232 Remote Control Interface.

The RS232 Interface accepts commands from an external controller via an optically isolated DB9 connector.

It connects to either of the 4 pin Expansion Ports on the rear of the Master Unit. Up to 8 Master Units can be controlled by daisy chaining their Expansion Ports.

All commands are in plain ACSII.

These commands would usually be issued from a PC running show control software, and/or possibly via hardware such as AMX.

Data is fixed at 9600 baud, N, 8, 1. The baud rate is not adjustable.

The RS232 Interface is wired as a DCE (Data Communication Equipment), so a serial lead fully wired straight through is all that is required to connect to a PC.

Commands can also be typed manually from Window's Hyper-terminal program. This is useful for testing.

If your terminal program allows sending one line of a text file at a time, it is possible to write a series of commands in a single .TXT file and then send one line at a time. Each line could contain only a single command or many commands. The Terminal program that shipped with Windows 3.1 allows sending a text file one line at a time and it works with Windows Me and XP Pro.

Notes can be added to a .TXT file. The start of a note is marked by a colon (:). All subsequent text is ignored until the next carriage return.

Notepad can be used to create suitable .TXT files. If using Wordpad or a word processor, choose Text Only (*.txt) or Text Document from the File Save dialogue box.

USB interface.

To control the RS232 Interface unit from a USB port, a USB to RS232 adaptor lead is required. These leads are not passive, but have electronics built in. An excellent USB to RS232 adaptor lead is the "EasySync Standard USB to RS-232 Converter" available from www.dontronics.com. See http://www.dontronics.com/usb_232.html. This lead is based on the FTDI USB chip and works better than most other USB/RS232 leads available.

Command Set.

A 4 or 5 character command is used depending upon the particular command. An execute character then uploads the just entered command(s) to the Master Unit. Depending on personal preference, the execute character can be any one of the following...

"X" for eXecute, "E" for EExecute, or the Enter Key.

Multiple commands can be entered before the execute character. This allows multiple cues to be preprogrammed and then activated simultaneously. Spaces and line feed characters are ignored as are all other unsupported characters.

RS232 Remote Control Interface (continued)

Command Format.



1st character. Always the letter "M". Short for Master, whose address is the next character.

2nd character. Master to be addressed. Supports Masters 1 to 8. Valid numbers are 0 to 8 inclusive.
0 = global address i.e. Masters 1 to 8 inclusive.
See the Maintenance section for details on setting/changing a Master Unit's address.

3rd/4th character. Channel to be addressed. Valid characters are numbers 0 to 14 inclusive or letters A and B. 0 = global address. i.e. Channels 1 to 14 inclusive. Letters A or B address Group Masters A and B respectively. (Channels 10 to 14 use 2 characters, one for each digit.)

Last character. Command byte. Choose one from the following...
If 3rd character was a number from 0 to 14 (a channel was addressed)...

- "A" Assign channel to Group A only
- "B" Assign channel to Group B only
- "C" Assign channel to Groups A & B
- "N" NO group assignment for that channel. (can use in conjunction with channel address = 0 to deselect all group assignments in one command)
- "G" Press the GO button
- "S" Press the STANDBY button
- "K" Kill Go & Standby lamps should they be on.

If 3rd character was a letter A or B (a Group Master was addressed)...

- "G" Press that Group Master's GO button
- "S" Press that Group Master's STANDBY button

Examples.

The last letter of each of these examples is "X", the execute character.

Go cue on channel 9 of Master 3

M39GX "M3" = Master #3, "9" = Channel 9, "G" = Press the channel's Go Button.

Standby cue on channel 10 of Master 3

M310SX "M3" = Master #3, "10" = Channel 10, "S" = Press the Standby Button.

Assign channel 6 on Master 2 to group B

M26BX "M2" = Master #2, "6" = Channel 6, "B" = Assign channel to Group B.

Send Standby Cues to all channels assigned to Group A on Master 1

M1ASX "M1" = Master #1, "A" = Group A, "S" = Press Group A's Standby Button.

Kill all cues on all Master Units. Stops all Go and Standby lamps from flashing.

M00KX "M0" = Masters #1 to 8, "0" = All 14 channels, "K" = Kill Go & Standby lamps should they be on.

Assign all channels to group B of Master 1.

Then Assign Channel 1 to group A of Master 1.

M10BX "M1" = Master #1, "0" = All 14 channels, "B" = Assign channels to Group B.

M11AX "M1" = Master #1, "1" = Channel 1, "A" = Assign channel to Group A.

These 2 commands can also be done on one line as "M10B M11A X"

To improve readability, spaces are permitted as required. All spaces are ignored.

TEST function.

TEST = Flash all Go & Standby LEDs.

ENTER, E or X = Exit test mode

ASCII Table

A section of the ASCII table.
Characters used by the RS232 interface are highlighted in red.

Decimal	Octal	Hex	Binary	Value	
013	015	00D	00001101	CR	(Carriage Return)
032	040	020	00100000	SP	(Space)
058	072	03A	00111010	:	(colon)
048	060	030	00110000	0	
049	061	031	00110001	1	
050	062	032	00110010	2	
051	063	033	00110011	3	
052	064	034	00110100	4	
053	065	035	00110101	5	
054	066	036	00110110	6	
055	067	037	00110111	7	
056	070	038	00111000	8	
057	071	039	00111001	9	
065	101	041	01000001	A	
066	102	042	01000010	B	
067	103	043	01000011	C	
068	104	044	01000100	D	
069	105	045	01000101	E	
070	106	046	01000110	F	
071	107	047	01000111	G	
072	110	048	01001000	H	
073	111	049	01001001	I	
074	112	04A	01001010	J	
075	113	04B	01001011	K	
076	114	04C	01001100	L	
077	115	04D	01001101	M	
078	116	04E	01001110	N	
079	117	04F	01001111	O	
080	120	050	01010000	P	
081	121	051	01010001	Q	
082	122	052	01010010	R	
083	123	053	01010011	S	
084	124	054	01010100	T	
085	125	055	01010101	U	
086	126	056	01010110	V	
087	127	057	01010111	W	
088	130	058	01011000	X	
089	131	059	01011001	Y	
090	132	05A	01011010	Z	

RS232 Hardware Configuration.

Any computer with a standard RS232 interface is able to control the RS232 Interface Unit.

The interface used is according to the EIA RS232C (V.24/V.28) standard.

Computer configuration:

Set the following data format and transmission rate:

- * 1 start bit
- * 8 data bits
- * no parity
- * 1 stop bits
- * 9600 baud

Signals:

The following signals are used for data transmission (9 pin SubD-Connector):

Receive Data (RXD): Pin 3
Signal Ground: Pin 5

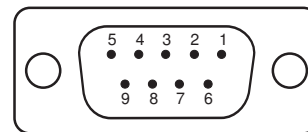

Pin side view of female DB9

The levels must be according to the EIA RS232C (CCITT V.28) standard.

No hardware handshake is implemented.

No x-on/x-off software handshake is implemented.

DTE = Data terminal equipment

DCE = Data communication equipment

AN IBM computer is a DTE.

9 pin connector: Transmits data on pin 3 and receives data on pin 2.

25 pin connector: Transmits data on pin 2 and receives data on pin 3.

The female connector of the RS232 Interface unit is a DCE.

It receives data on pin 3. The RS232 Interface unit does not transmit data.

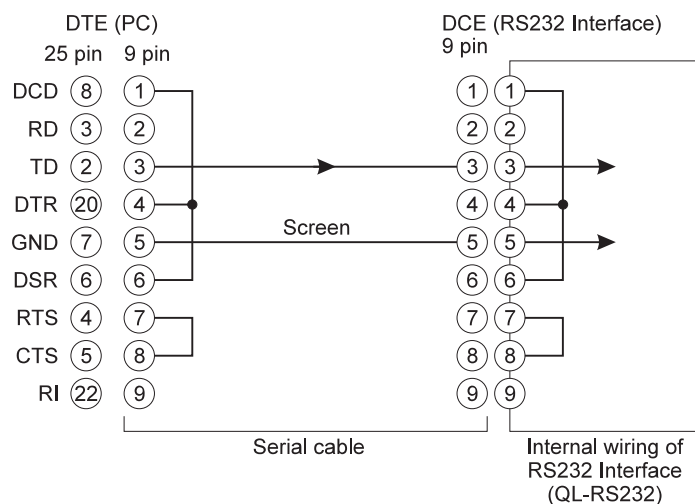

Serial Cable:

1: Use a fully wired straight through serial cable. (Modem cable)

2: If not using a fully wired cable, only 1 core and a screen is required.

Link pin 1 to 4 to 6 and pin 7 to pin 8 as per the drawing above.

Officially, the maximum length is 15 metres (50 feet), but in practice greater lengths usually work satisfactorily.

Maintenance

Master Setup.

The Master Unit has a number of configurable options.

- 1:** The Master Unit can be assigned an address for use with the RS232 Remote Control Interface (QL-RS232). Factory default is #1. Up to 8 Master Units can be controlled from one QL-RS232.
- 2:** Calls from Outstations via the Acknowledge button can be disabled. Factory default is enabled.
- 3:** Enable/disable the Beep button. Factory default is enabled.
- 4:** Link/unlink the Master Group buttons between Master Units when the RS232 Interface Unit is connected. Factory default is linked.

To enter the Master Unit's Set Up Routine, press and hold all 3 buttons of channel 1 while turning on the mains power.

Once done, press Group "B" Master Go button to exit and save changes.

1: Set Master Unit address.

The current Master Unit address is displayed using the fault LEDs of channels 1 to 8. Address #5 = fault LED #5 on.

Change the address by pressing the white Dimmer button.

Valid addresses are 1 to 8.

Unless the RS232 Remote Control unit is used, the address can be set to any value. Factory default is address #1

2: Calls from Outstations.

The current status of this function is displayed in channel 2's Go LED.

Enabled = LED on. Factory default is enabled.

Use channel 2's Go Button to toggle it on and off.

3: Enable/disable the Beep button.

Enable/disable the Beep button.

The current status of this function is displayed in channel 3's Go LED.

Enabled = LED on. Factory default is enabled.

Use channel 3's Go Button to toggle it on and off.

4: Link/unlink the Master Group buttons.

The Master Group buttons are normally linked between multiple Master Units. When the RS232 Interface Unit is connected, it may be desirable to have the Master units not linked.

This option only has effect when the RS232 Interface Unit is connected.

The current status of this function is displayed in channel 4's Go LED.

Link = LED on. Factory default is enabled.

Diagnostic Mode.

This mode alternately flashes the Go and Standby LEDs on all substations. This allows the operation of the LEDs and data communications to be verified.

Enter the diagnostic mode by pressing both of the Group "B" Master buttons for approximately 4 seconds until all the LEDs on the Master Unit light. Release the buttons. The diagnostic mode is now active.

Exit the Diagnostic Mode by pressing either of the Group "B" Master buttons or by cycling the mains power.

Any Fault LEDs lighting briefly is an indication of data communication errors. The usual causes are excessive cable lengths and/or too many substations at the end of a long cable run.

Maintenance (continued)

Lamp and Button test.

Press and hold the 3 right hand most buttons for approximately 4 seconds until all the LEDs on the Master Unit light. Release the buttons. The LEDs will now chase in a slowly falling pattern across all channels. The red "short" LED will flash. The power LED stays on all the time. This test will verify that there are no dead LEDs.

Pressing any button will interrupt the chase and cause a LED associated with that button to light. Press each channel button in turn, noting that only one LED should light for each button.

Pressing the group "A" buttons will light LEDs on the left hand half of the channels. Pressing the group "B" buttons will light LEDs on the right hand half of the channels.

It will return to the chase mode a couple of seconds after the release of all buttons. To exit the "Lamp and Button test mode" and return to normal operation, cycle the mains power or press all 3 buttons again.

Outstation Address.

The address of each outstation is stored in the Outstation's EEPROM. This is programmed during manufacture to correspond with the front panel label.

The address stored in the Outstation can be confirmed by the following routine:

- 1: Hold down the Acknowledge button while plugging in the XLR connector.
- 2: The Outstation's standby LED will flash a number of times corresponding to the unit's programmed address.
- 3: To exit this routine, release the Acknowledge button and unplug the XLR, wait a few seconds and plug it back in again.

Changing The Outstation's Address.

On occasions it may be necessary to reprogram the Outstation's address. This will need to be done if a new PCB is fitted or the microcontroller is changed. It can also be done on a temporary basis if a spare Outstation is used to replace a failed or damaged one. The replacement can have its address changed so that the cue sheet doesn't need to be changed.

- 1: To enter the address programming mode, hold down the Acknowledge button while plugging in the XLR connector.
- 2: Release the Acknowledge button when the Standby LED starts flashing. It will flash a number of times corresponding to the Outstation's programmed address.
- 3: Press the Acknowledge button "n" times to program a new address. It will flash the new address after a 2 second pause. If you stuff it up, just repeat step 3.

Valid addresses are 1 to 14 inclusive. More than 14 presses of the Acknowledge button are ignored.

Once a new address has been programmed, exit the address programming mode by doing any one of the following 3 options ...

- a: Unplug the XLR, wait a few seconds and plug it back in again.
- b: Nothing. It will keep flashing its address for about 30 seconds and then it will reboot.
- c: Press and hold the Acknowledge button until it reboots (this takes about 3 seconds)

Specifications

Master Unit.

Power.

110/230/240V 50/60Hz mains power. Specify at time of ordering.
60 watts maximum.

Connectors.

Output: One each of 3 pin XLR chassis male and female connector.
Total cable length is greater than 1,000 metres (3,300 feet) long. Further with low loss cables.

Data is between pins 2 and 3. Power is nominal +30V DC common mode on pins 2 and 3 and current limited to approximately 1.5 Amps.

Power return is via Pin 1.

Digital data via nominal 20kHz FM signal. Nominal baud rate: 10kBd

Expansion Port: Parallel 4 pin locking metal connector.

Expansion Port cables maximum length: 30 metres (100 feet)

Pins 1: Ground

Pins 3 & 4: RS485

Pin 2: nominal +30V DC. Current limited to approximately 150mA.

Dimensions.

2 unit high 19" rack mount all metal chassis.

Width: 482mm (19.0")

Height: 89mm (3.5")

Depth: 260mm (10.2") excluding connectors.

Where rack depth is restricted, it has been reported that people have removed the front panel from the chassis and mounted it direct to their rack. The front panel has all of the electronics attached and has a maximum depth of 50mm (2"). The power supply and rear panel connectors being mounted where convenient. This is not recommended however, as dangerous voltages may be exposed.

Weight.

6.0 kg (13.2 pounds)

Outstations.

Power.

From the Master Unit via the interconnecting 3 pin XLR lead.

Typically 30mA each, rising to a maximum of 80mA each when the supply volts are low at the end of very long cable runs.

Connectors.

One each of 3 pin XLR chassis female and male. They are both wired in parallel so that either may be used as an input and the other for loop through.

Finish.

Die cast aluminium boxes and are powder coated in satin black.

Mounting holes

4 slots 3.8 mm x 10 mm (0.15" x 0.40")

Standard & Relay Outstations

Dimensions.

Width: 94.0 mm (3.70")

Height: 148 mm (5.83")

Depth: 34 mm (1.35")

Weight.

350g (11.3 ounces)

Small Footprint Outstations

Dimensions.

Width: 110mm (4.3")

Height: 58mm (2.3")

Depth: 30mm (1.2")

Weight.

225g (7.9 ounces)

Outstation Mechanical Details

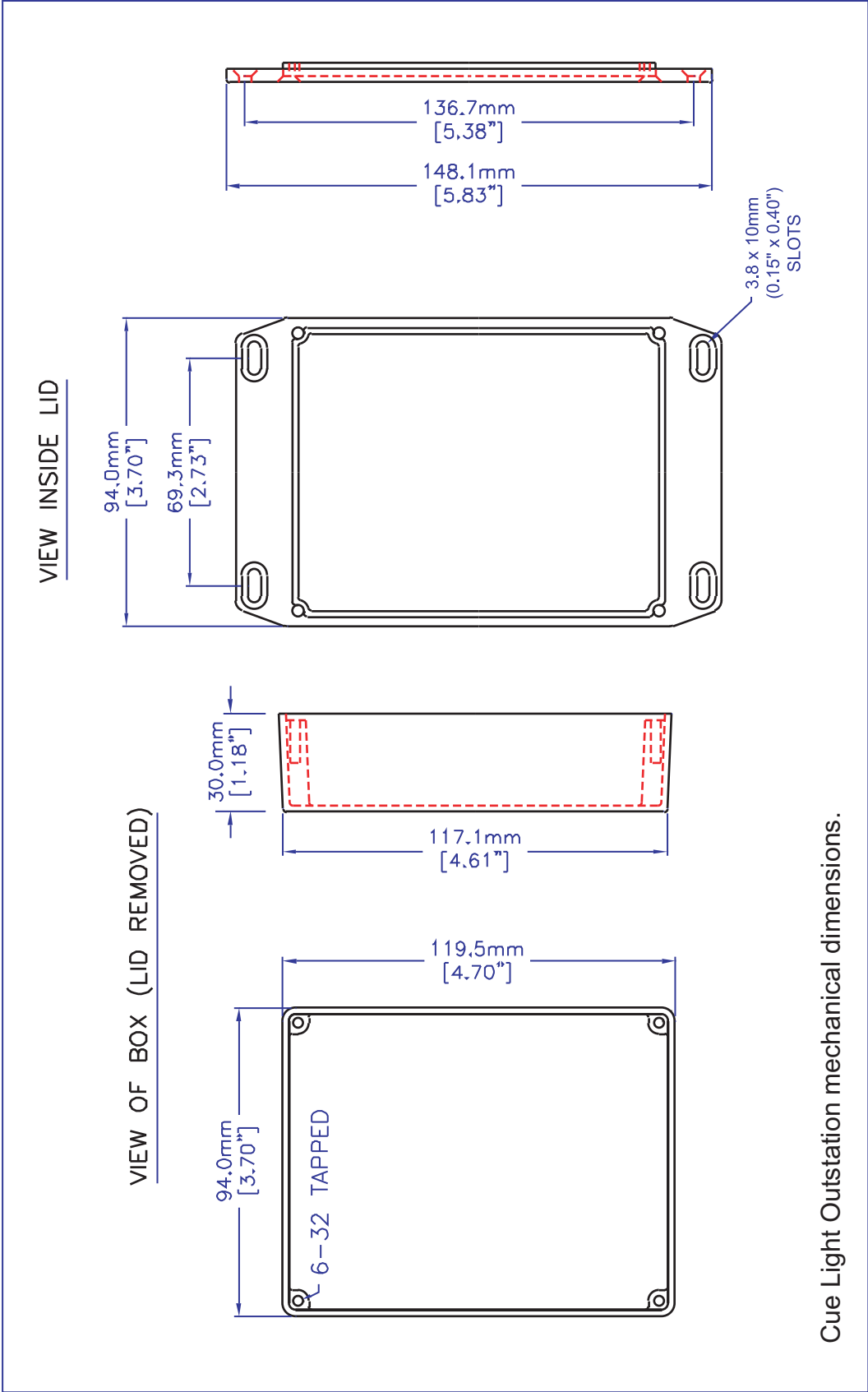

Cue Light Outstation mechanical dimensions.

TECHNICAL DATA

AWG/METRIC CONDUCTOR CHART

AWG	STRANDING	APPROX. O.D.		CIRCULAR MIL AREA	SQUARE		WEIGHT LBS./ 1000 FT.	WEIGHT KG/ KM	D.C. RESISTANCE OHMS/ 1000 FT.	D.C. RESISTANCE OHMS/ K/ M
		INCHES	MM		INCHES	MM				
36	Solid	0.0050	0,127	25.0	—	0,013	0.076	0,113	445.0	1460,0
36	7/44	0.006	0,152	28.0	—	0,014	0.085	0,126	371.0	1271,0
34	Solid	0.0063	0,160	39.7	—	0,020	0.120	0,179	280.0	918,0
34	7/42	0.0075	0,192	43.8	—	0,022	0.132	0,196	237.0	777,0
32	Solid	0.008	0,203	67.3	0.0001	0,032	0.194	0,289	174.0	571,0
32	7/40	0.008	0,203	67.3	0.0001	0,034	0.203	0,302	164.0	538,0
32	19/44	0.009	0,229	76.0	0.0001	0,039	0.230	0,342	136.0	448,0
30	Solid	0.010	0,254	100.0	0.0001	0,051	0.30	0,45	113.0	365,0
30	7/38	0.012	0,305	112.0	0.0001	0,057	0.339	0,504	103.0	339,0
30	19/42	0.012	0,305	118.8	0.0001	0,061	0.359	0,534	87.3	286,7
28	Solid	0.013	0,330	159.0	0.0001	0,080	0.48	0,72	70.8	232,0
28	7/36	0.015	0,381	175.0	0.0001	0,072	0.529	0,787	64.9	213,0
28	19/40	0.016	0,406	182.6	0.0001	0,093	0.553	0,823	56.7	186,0
27	7/35	0.018	0,457	219.5	0.0002	0,112	0.664	0,988	54.5	179,0
26	Solid	0.016	0,409	256.0	0.0002	0,128	0.770	1,14	43.6	143,0
26	10/36	0.021	0,533	250.0	0.0002	0,128	0.757	1,13	41.5	137,0
26	19/38	0.020	0,508	304.0	0.0002	0,155	0.920	1,37	34.4	113,0
26	7/34	0.019	0,483	277.8	0.0002	0,142	0.841	1,25	37.3	122,0
24	Solid	0.020	0,511	404.0	0.0003	0,205	1.22	1,82	27.3	89,4
24	7/32	0.024	0,610	448.0	0.0004	0,229	1.36	2,02	23.3	76,4
24	10/34	0.023	0,582	396.9	0.0003	0,202	1.20	1,79	26.1	85,6
24	19/36	0.024	0,610	475.0	0.0004	0,242	1.43	2,13	21.1	69,2
24	41/40	0.023	0,582	384.4	0.0003	0,196	1.16	1,73	25.6	84,0
22	Solid	0.025	0,643	640.0	0.0005	0,324	1.95	2,91	16.8	55,3
22	7/30	0.030	0,762	700.0	0.0006	0,357	2.12	3,16	14.7	48,4
22	19/34	0.031	0,787	754.1	0.0006	0,385	2.28	3,39	13.7	45,1
22	26/36	0.030	0,762	650.0	0.0005	0,332	1.97	2,93	15.9	52,3
20	Solid	0.032	0,813	1020.0	0.0008	0,519	3.10	4,61	10.5	34,6
20	7/28	0.038	0,965	1111.0	0.0009	0,562	3.49	5,19	10.3	33,8
20	10/30	0.035	0,889	1000.0	0.0008	0,510	3.03	4,05	10.3	33,9
20	19/32	0.037	0,940	1216.0	0.0010	0,620	3.70	5,48	8.6	28,3
20	26/34	0.036	0,914	1031.9	0.0008	0,526	3.12	4,64	10.0	33,0
20	41/36	0.036	0,914	1025.0	0.0008	0,523	3.10	4,61	10.0	32,9
18	Solid	0.040	1,020	1620.0	0.0013	0,823	4.92	7,32	6.6	21,8
18	7/26	0.048	1,219	1769.6	0.0014	0,902	5.36	7,98	5.9	19,2
18	16/30	0.047	1,194	1600.0	0.0013	0,816	4.84	7,20	8.5	21,3
18	19/30	0.049	1,245	1900.0	0.0015	0,969	5.75	8,56	5.5	17,9
18	41/34	0.047	1,194	1627.3	0.0013	0,830	4.92	7,32	6.4	20,9
18	65/36	0.047	1,194	1625.0	0.0013	0,829	4.91	7,31	6.4	21,0
16	Solid	0.051	1,290	2580.0	0.0020	1,310	7.81	11,60	4.2	13,7
16	7/24	0.060	1,524	2828.0	0.0022	1,442	8.56	12,74	3.7	12,0
16	65/34	0.059	1,499	2579.9	0.0020	1,316	7.81	11,62	4.0	13,2
16	26/30	0.059	1,499	2600.0	0.0021	1,326	7.87	11,71	4.0	13,1
16	19/29	0.058	1,473	2426.3	0.0019	1,327	7.35	10,94	4.3	14,0
16	105/36	0.059	1,499	2625.0	0.0021	1,339	7.95	11,83	4.0	13,1
14	Solid	0.064	1,630	4110.0	0.0032	2,080	12.40	18,50	2.6	8,6
14	7/22	0.073	1,854	4480.0	0.0035	2,285	13.56	20,18	2.3	7,6
14	19/27	0.073	1,854	3830.4	0.0030	1,954	11.59	17,25	2.7	8,9
14	41/30	0.073	1,854	4100.0	0.0032	2,091	12.40	18,45	2.5	8,3
14	105/34	0.073	1,854	4167.5	0.0033	2,125	12.61	18,77	2.5	8,2

Web Site: www.alphawire.com
 Email: info@alphawire.com

Toll Free: 1-800-52 ALPHA • Telephone: 908-925-8000 • Fax: 908-925-6923
 Europe/UK Telephone: +44 (0) 1932 772422 • Europe/UK Fax: +44 (0) 1932 772433



Warranty

The Leon Audio Digital Theatre Cue Light is guaranteed for two years from date of original purchase against defects in workmanship and materials. If such malfunction occurs, the item will be repaired or replaced (at our option) without charge for materials or labour if delivered prepaid to THE LEON AUDIO COMPANY. Unit will be returned prepaid. Warranty does not cover finish or malfunction due to abuse or operation at other than specified conditions. Repairs by other than THE LEON AUDIO COMPANY or authorized agents will void this guarantee.



62 Edgeware Road, Aldgate, South Australia, 5154
Phone (08) 8339 3865 Fax (08) 8370 8780
Intn'l Phone +61 8 8339 3865 FAX +61 8 8370 8780
www.LeonAudio.com.au